



in.tune



Fully and truly waterproof
am-fm receiver / mp3 / cd player

User's manual



Designed to be used in
humid environments.

Aware3
by gecko





Aeware 3
by gecko

Table of contents

features	3
warning	4
about compact discs	6
function description	8
icon description	9
instructions	
- general	10
- radio mode	13
- weather band mode	15
- auxiliary mode	16
- cd mode	17
- mp3 mode	20
basic operations of optional IR remote control (IRMT-4)	22
parts list	24
installation & connections	25
accessories	33
specifications	34



 Australian Spa Parts



Congratulations!

Congratulations on the purchase of your very own in.tune CD player! You own one of the industry's best entertainment system. This system is UV, salt spray and water resistant and is designed to provide hours of troublefree usage. Take a moment to read through this manual and become familiar with the operations and features of your new product.

Main features

- Fully waterproof
- 50 Watts x 4 amplifiers
- AM/FM tuner
- Automatic/manual tuning
- Compatible with European and North American radio stations
- Multiple station presets
- CD, CD-R and CD-RW
- MP3 player with ID3 tag
- 7-channel weather band
- Built-in IR remote sensor
- Compatible with Aeware's auxiliary controls (in.k155 & in.k455)
- Fader key (Aeware's exclusive feature)
- LCD display and clock functions

**WARNING**

Before installing or connecting the unit, please read the following.

DO NOT DISASSEMBLE OR ALTER.

Doing so may result in an accident, fire or electrical shock.

USE THE CORRECT AMPERE RATING WHEN REPLACING FUSES.

Failure to do so may result in fire or electrical shock.

DO NOT BLOCK VENTS OR RADIATOR PANELS.

Doing so may cause heat to build up inside and may result in fire.

DO NOT PLACE HANDS, FINGERS OR FOREIGN OBJECTS IN INSERTION SLOTS OR GAPS.

Doing so may result in personal injury or damage to the product.

DO NOT PLACE HANDS OR FINGERS ON RADIATOR PANELS.

Doing so may result in personal injury.

DO NOT USE FOAM TO ISOLATE THE UNIT.

Doing so may cause heat to build up inside and may result in fire.

INSTALL UNIT 1" AWAY FROM OTHER SURFACES.

Make sure to leave a clearance of at least 1" from other surfaces.

INSTALL MOUNTING STRAP.

The in.tune must always be installed with the mounting strap firmly-

fixed to a solid part. Failure to do so may result in damage to the unit and annulment of the warranty, (see page 32 for more details).

DO NOT INSERT A WET CD DISK IN YOUR IN.TUNE

Do not insert a wet CD disk in the disk slot of your in.tune receiver/CD player. Doing so will void the warranty of your in.tune.

**PRECAUTIONS****Damaged disc**

Do not attempt to play a cracked, warped or damaged disc. Playing such a disc could severely damage the mechanism.

Maintenance

If you have problems, do not attempt to repair the unit yourself. Return it to your dealer or service station for servicing.

Accessory parts

Be sure to use only the specified accessory parts. Use of other than designated parts may damage this unit internally or may not securely install the unit in place. This may cause parts to become loose resulting in hazards or product failure.

Disposal of the product

The appliance (or the product) must be disposed of separately in accordance with the local waste disposal legislation in force.

**WARNING**

When this equipment is provided as an audio/video component for spas, UL 1563 - 5th edition requires that the following instructions (or equivalent) be provided as part of the instruction manual for the spa equipment.

PREVENT ELECTROCUTION

Do not connect any auxiliary components (for example cable, additional speakers, headphones, additional audio/video components, etc) to the system.

These units are not provided with an outdoor antennae; when provided, it should be installed in accordance with Article 810 of the National Electrical Code, ANSI/NFPA 70.

Do not service this product yourself as opening or removing covers may expose you to dangerous voltage or other risk of injury. Refer all servicing to qualified service personnel.

When the power supply connections or power supply cord(s) are damaged; if water is entering the audio/video compartment or any electrical equipment compartment area, if the protective shields or barriers are showing signs of deterioration; or if there are signs of other potential damage to the unit, turn off the unit and refer servicing to a qualified service personnel.

**CAUTION- RISK OF ELECTRIC SHOCK !**

DO NOT LEAVE COMPARTMENT DOOR OPEN.

REPLACE COMPONENTS ONLY WITH IDENTICAL COMPONENTS.

DO NOT OPERATE THE AUDIO/VIDEO CONTROLS WHILE INSIDE THE SPA.

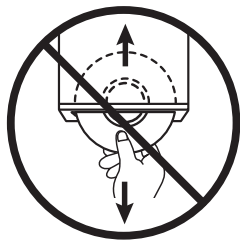

Never attempt the following

Do not grip or pull out the disc while it is being pulled back into the player by the automatic reloading mechanism. Do not attempt to insert a disc into the unit when power is off.

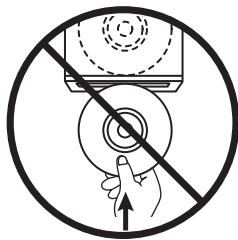

Inserting a disc

Make sure label side is facing up when you insert the disc.

Do not try to insert another disc when one has already been inserted.

If a disc is inserted incorrectly, the "DISC ERROR" message will be displayed twice, then CD player will return to Radio mode. If the player continues to display "DISC ERROR" message, push the **Reset** button with a pointed object such as a ballpoint pen.



CD logo marks

Use only compact discs with the label side showing the CD logo marks above.

Correct performance can't be guaranteed if you use unspecified compact discs.

A CD-R or CD-RW that hasn't been finalized (closed) or on which a recording failure has occurred can't be played.

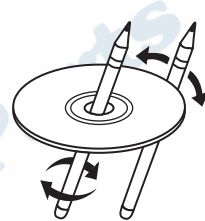

New discs

New discs may sometimes have some roughness around the edges. If such discs are used, the player may not work properly. Use a ballpoint pen or the like to remove any roughness from the edge of the disc.



Irregular shaped discs

Be sure to use round shape discs only for this unit and never use any special shape discs. Using a special shape disc may cause damage to the mechanism.

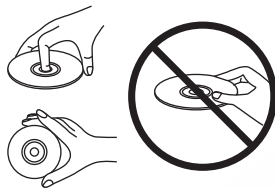

Correct handling

Handle the disc by its edge. To keep the disc clean, do not touch the surface. Never stick paper or tape on the surface of the disc or mark the surface with a pencil or pen.



Disc cleaning

Fingerprints, dust or soil on the surface of the disc could cause the CD player to skip. To remove these, wipe the playing surface with a clean, soft cloth from the center of the disc to the outer edge.

Never use solvents, such as commercially available cleaners, anti-static spray or thinner to clean discs.

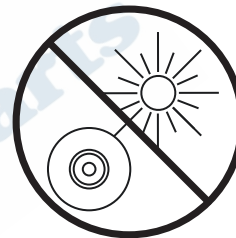

Storage

Do not expose discs to direct sunlight or any heat source. Do not expose discs to excess humidity or dust.

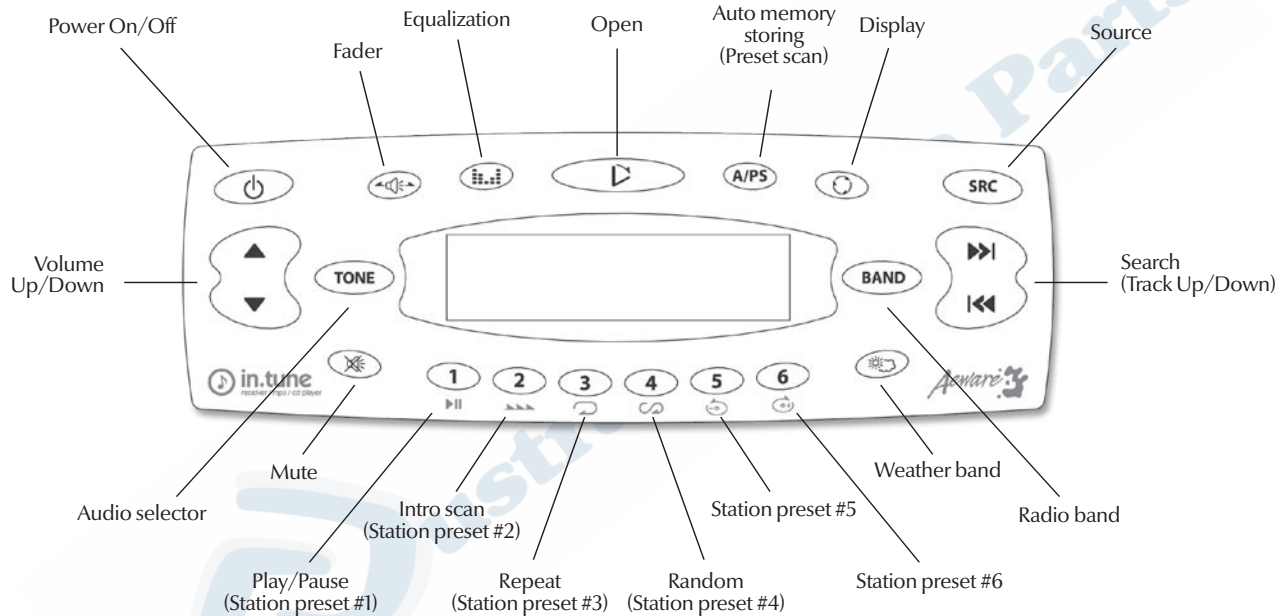

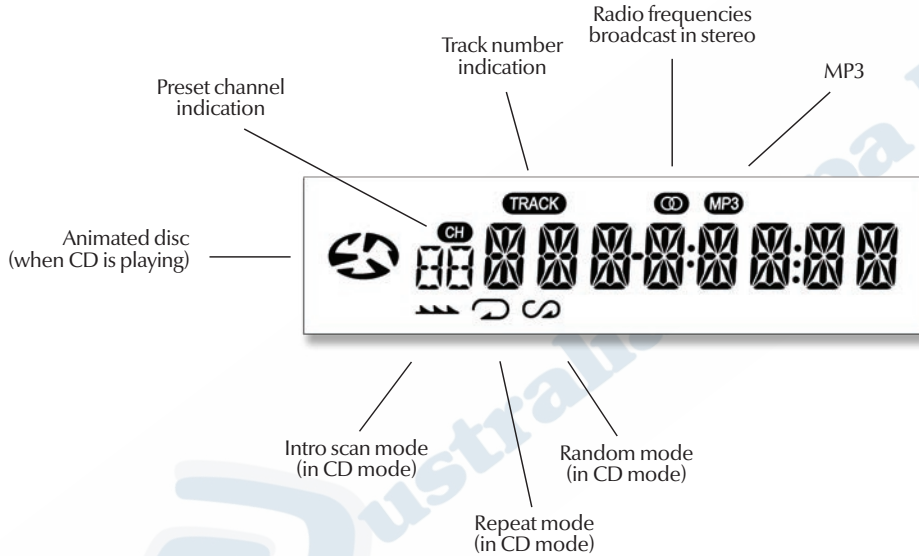

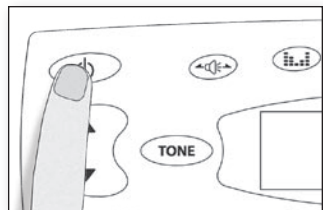

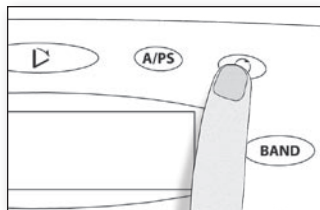

Power on/off

Press **Power** to turn system on or off.



Clock setting

To set the time, press and hold **Display** for 3 seconds.

Time then flashes on the display. Set the hours by using **Track up** or **down**. 

Press **Display** again. Set the minutes.

When done, press and hold **Display** again for 3 seconds to exit (or simply wait for 5 seconds).

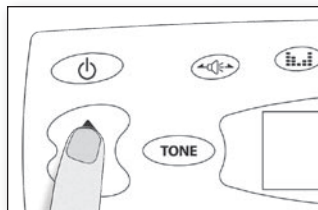

Volume up or down

Press **Volume up** or **down** to increase or decrease volume.

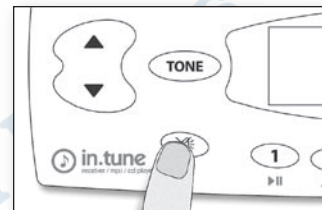

Mute

Press **Mute** to mute the audio output. Press again to return to previous volume level.

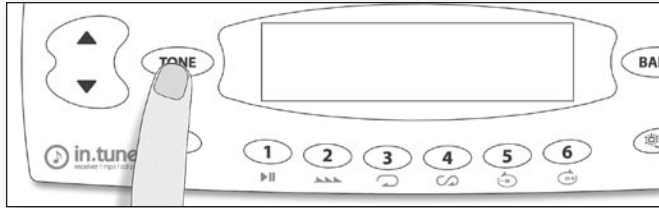

Tone

Use **TONE** to select either (in order): volume, bass, treble, balance or fader. To change the desired parameter, use **Volume up** or **down**. ▲▼

Bass control: Adjusts the amount of low frequency that you hear.

Treble control : Adjusts the amount of high frequency that you hear.

Balance control: Adjusts the amount of sound output to the left and right speakers.

Fader control: Adjusts the amount of sound output (see **Fader** key on next page).

Note: Bass and Treble settings are available only if EQ is set to DSP Off.

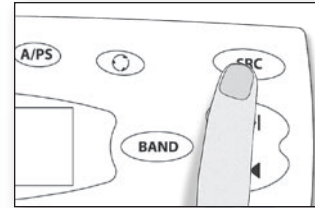

Source SRC

Pressing **SRC** will allow you to select a source between the following (in order):

Tuner, CD and Aux.

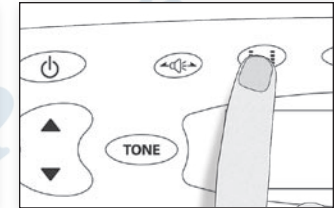

Equalization

Successive presses on **EQ** will allow you to choose from DSP Off, Jazz, Pop, Classic, Rock or Vocal.

Press and hold EQ to enable or disable "LOUD" function.

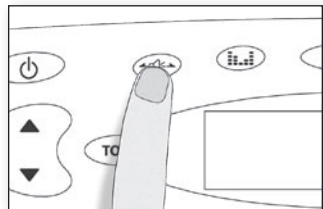

Fader 

Successive presses on **Fader** will allow you to select from one of the following adjustments:

FAD-FRONT: Front speaker only.

FAD-REAR: Rear speaker only.

FAD-ALL: Front and rear speakers.

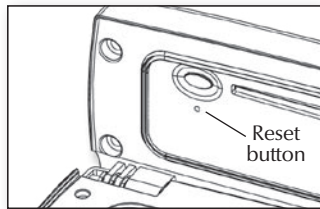

Reset button

If keys on the front panel become locked up, i.e. keys do not function at all, or the display area becomes unreadable, use a ballpoint pen to press the **Reset button**.

Pressing **Reset button** clears all memory (except station presets) and resets the display to its default settings. The clock will lose the set time.

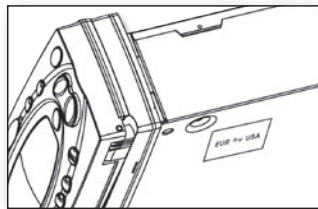

USA/Europe switch

You can switch from American (USA) to European radio stations. To do so, power down the unit first. Then lift up the sticker which is located under the CD player.

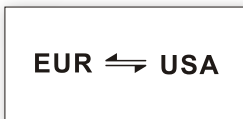

Switch from American (USA) to European or vice-versa, as indicated on the sticker then put sticker back in place and power up the unit.



Protective cover

We recommend to install the protective cover on the front panel when CD player is not used for a long period of time or when the surface on which the CD player is installed needs some cleaning.

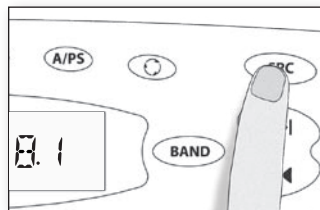

Selecting radio mode **SRC**

Press **SRC** until Radio mode is displayed.

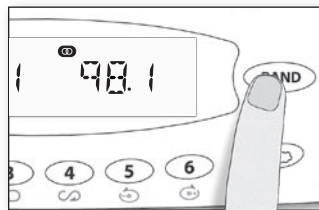

Selecting radio band **BAND**

Press **BAND** to select between FM1, FM2, FM3, AM1, AM2 and WB (weather band).

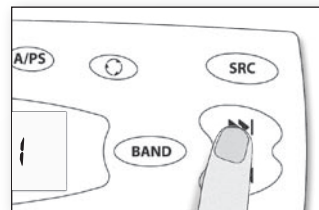

Tuning up or down **Track up** **Track down**

Press **Track up** to manually adjust frequency up. Press and hold **Track up** to make a seek up to the next station. Scan mode stops as soon as a strong station is found.

Press **Track down** to manually adjust frequency down. Press and hold **Track down** to make a seek down to the next station. Scan mode stops as soon as a strong station is found.



Preset stations **1 2 3 4 5 6**

Any station may be preset simply by pressing and holding one of the keys (1 to 6).

Press one of the keys (1 to 6) to recall the stored stations.

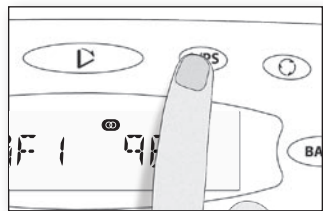

Auto scan **A/PS**

Press **A/PS** to scan preset stations. The tuner will scan up and wait for a few seconds, then scan up again.

Once the desired station is found, press **A/PS** again to stop Scan mode.

Pressing and holding **A/PS** will scan and store stations automatically in each memory (6) of the selected band.

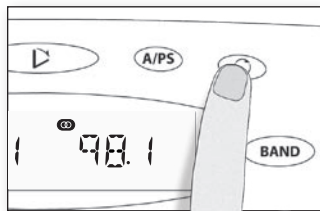

Display information

Press **Display** to switch between the following display information:

Frequency - Clock (clock is displayed for 5 seconds only).

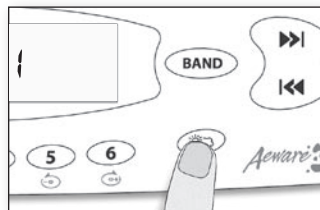

Selecting weather band mode

Press **Weather** to access Weather band mode (or press **BAND** in Tuner mode until WB is displayed).

It automatically skips to the strongest weather channel.

Press **Weather** again to turn off weather band radio and return to previous mode.

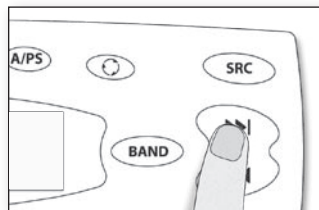

Selecting weather station

Use **Track up** to go to the next memorized weather channel (CH1 to CH7).

Use **Track down** to go to the previous memorized weather channel (CH1 to CH7).

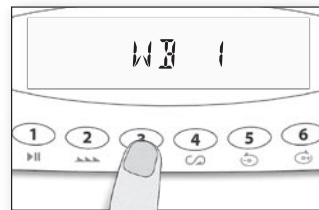

Preset weather station

In Weather band mode, use keys **1** to **6** to choose from CH1 to CH6.

Only CH7 is not accessible through preset key.

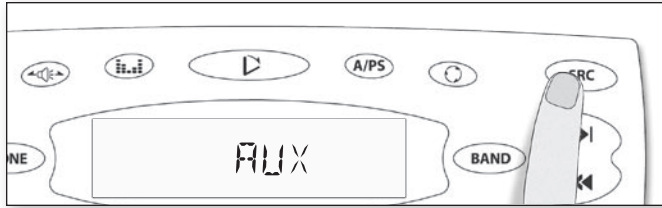

Auxiliary input

Press **SRC** until the display reads "AUX", which indicates that the auxiliary unit is playing.

This mode allows to play sound from external source such as a TV, video, etc. (please refer to "installation & connections" section for the connection of such external devices).

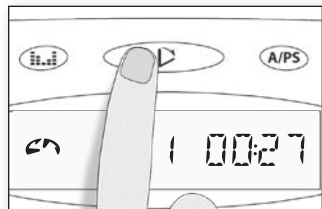

Inserting compact disc ▶

Press **Open** to flip down the front panel and access the CD slot. Insert CD into the CD slot.

The CD will load and play automatically.

If the CD does not auto load, do not force it. Press the **Eject** button as you may already have a disc inserted.

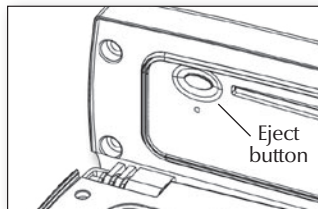

Ejecting compact disc

To eject CD, flip-down front panel must be open, then press **Eject** button, located on the left.

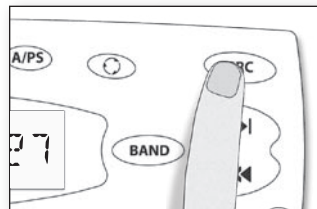

Selecting CD mode SRC

Press **SRC** until CD mode is displayed.

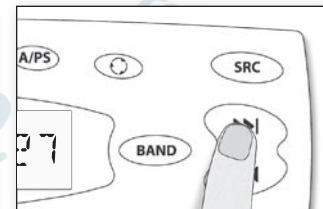

Track up or down ◀▶

To change music track, simply press **Track up** or **down**.

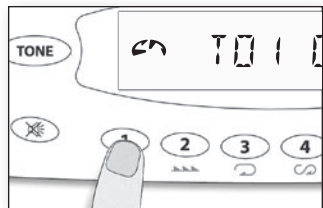

Pause mode ▶|| 1

To pause the playing of a disc, press **Pause**.

To resume play, press key again.



Intro scan mode ≡ 2

You can preview each song of the current disc for about 10 seconds. Simply press **Scan**.

Press again to turn off this feature.



Repeat mode ↺ 3

To play a song repeatedly, press **Repeat**.

Press again to turn off this feature.

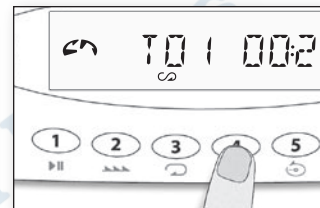

Random mode ∞ 4

Press **Random** to play song tracks randomly.

Press again to turn off this feature.

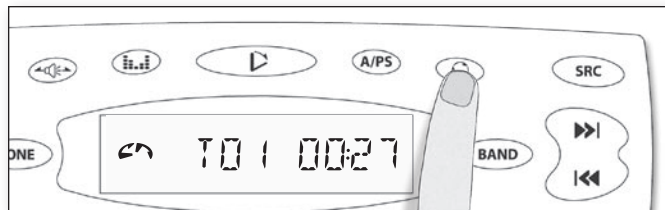

Display information

Press **Display** to switch between the following display information:
Track no. / Playtime - Clock (clock is displayed for 5 seconds only).

If you inserted a CD containing MP3 files, a different display info will appear if you press **Display**:
Track no. / Playtime - Folder no. / Track no. - Folder name - File name - Song name - Artist's name - Album name - Clock (clock is displayed for 5 seconds only).

The system can only display the first 8 letters of ID3 tags. If the recorded information is longer than 8 letters, text will scroll to the left once, then the 8 first letters will be displayed.

If specific info has not been recorded on an MP3 disc, NO FOLD, NO TRK, NO TLT, NO ALBM, NO ART will be displayed.



Playback order of MP3 files

- A directory that does not include an MP3 file is skipped.
- We recommend that you make no more than two levels for each disc.
- Maximum number of folders: 256
- Maximum number of folder levels: 8
- Maximum number of characters for MP3 file name and folder name: 32
- Sampling frequency: 16 kHz, 22.05 kHz, 24 kHz, 32 kHz, 44.1 kHz, 48 kHz
- Bit rates: 8-320 Kbps
- MP3 decoding format: MPEG 1 & 2 Audio Layer 3
- Folder names and file names can be displayed with up to 8 characters (see **Display** key).
- The characters A-Z, 0-9 can be displayed on this unit, other characters may not be displayed correctly.
- ID3 tag is supported (see **Display** key).

Reading files on a disc

When a disc containing MP3 data is loaded, the unit checks all the data on the disc. If the disc contains a lot of folders with many levels, it takes a longer time to start playback.

In addition, it may take time for the unit to move to the next MP3 file and Fast Forward function may not be performed smoothly.

MP3 playing order

When selected to play, files and folders are accessed in the order in which they were written by the CD writer. Therefore, the playing order may not be the same as the order in which they are expected to be played.

For example, a disc with the following folder/file hierarchy is subject to Folder Select, File Select and playback order as shown on next page.



Example of a disc's folder/file hierarchy

Level 1 Level 2 Level 3 Level 4 Level 5

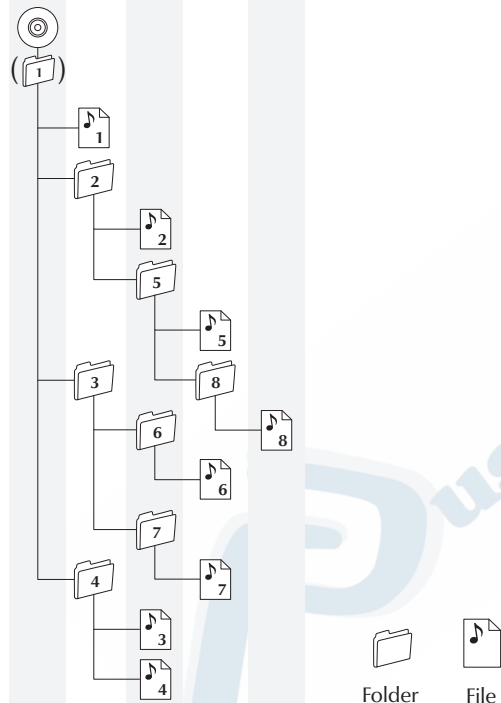

Operation of keys

Press 5 to select folder down

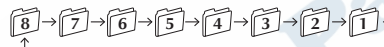

Press 6 to select folder up



Press (Track Down) to select file down

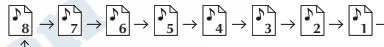

Press (Track Up) to select file up



Press and hold 5 to return 10 files behind.

Press and hold 6 to go 10 files forward.

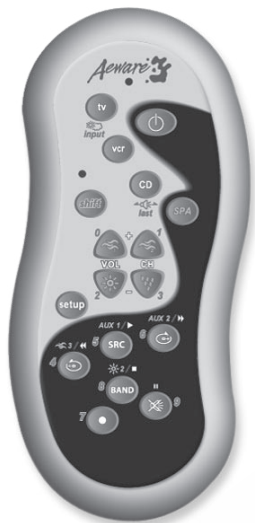



















Sold separately

* The code for your in.tune is **0101**.

Key/Icon	Description
	When pressing a key, the red LED blinks to show that the remote control is working properly and sending signals.
	Use setup for all programming sequences. Refer to the remote control (IRMT-4) instructions manual for detailed explanation on programming sequences.
	Press Power to turn system on or off.
	Press CD to control the in.tune*.
	Press VOL + or - to increase or decrease volume.
	Radio mode: Press CH + or - to go to the next or previous preset station. Press and hold CH + or - to make a seek up or down to the next station. Scan mode stops as soon as a strong station is found.
	Weather band mode: Press CH + or - to go to the next or previous memorized station.
	CD mode: Press CH + or - to change music track. Press and hold Track Up or Down to fast forward or rewind.
	MP3 mode: Press CH + or - to select file up or down.



Key/Icon	Description
	Pressing SRC will allow you to select a source between the following (in order): Tuner, CD, Aux.
	MP3 mode: Press  to select folder down.
	MP3 mode: Press  to select folder up.
	Radio mode: Press BAND to select between FM1, FM2, FM3, AM1, AM2 and WB (weather band).
	Press  to mute the audio output. Press again to return to previous volume level.
	While holding shift , press one of the following keys to select secondary functions (the LED lights up above key).
 + 1,2,3,4,5,6	Radio mode: Use these keys (1-6) to recall the stored stations. Any station may be preset simply by pressing and holding one of the keys (1 to 6).
 +  	Press  to access Weather band mode. Press  again to turn off weather band radio and return to previous mode.
 +  	Successive presses on  will allow you to select from one of the following adjustments: FAD-FRONT: Front speaker only. FAD-REAR: Rear speaker only. FAD-ALL: Front and rear speakers.

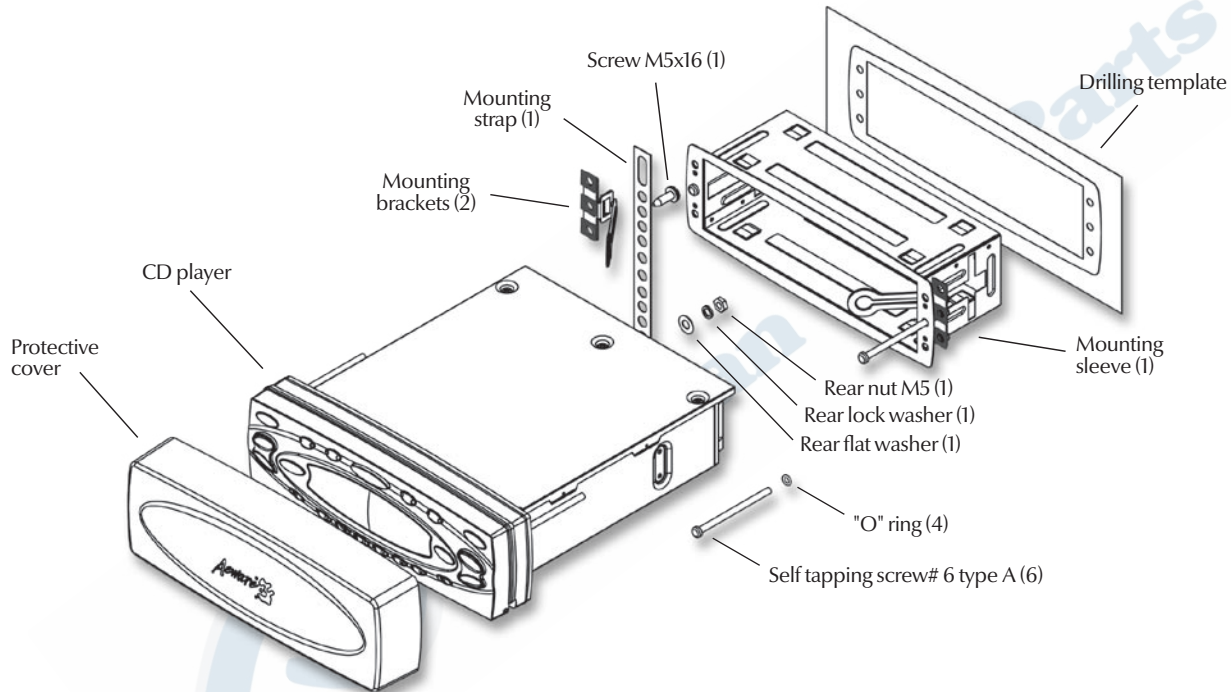



Wiring

Yellow wire (w/fuse)

Connect this wire to a constant +12 volt power source (a power source that is not controlled by the ignition key).

Red wire

Connect this wire to a switched +12 volt power source (a power source turned on and off by the ignition key).

Orange wire

Connect this wire to the light control switch (dimmer control). If no lighting circuit is available, tape off the end of this wire to prevent shorting out of the unit.

Blue wire

Connect this wire to the (+) power antenna activation circuit. If no power antenna exists, tape off the end of this wire to prevent shorting out of the unit.

Black wire

Connect this wire to the frame of the vehicle (ground or ground power source). This wire is the chassis grounding wire for the unit.

White wire

Connect this wire to the left front speaker (+) positive terminal or wire.

White wire with black stripe

Connect this wire to the left front speaker (-) negative terminal or wire.

Gray wire

Connect this wire to the right front speaker (+) positive terminal or wire.

Gray wire with black stripe

Connect this wire to the right front speaker (-) negative terminal or wire.

Green wire

Connect this wire to the left rear speaker (+) positive terminal or wire.

Green wire with black stripe

Connect this wire to the left rear speaker (-) negative terminal or wire.

Purple wire

Connect this wire to the right rear speaker (+) positive terminal or wire.

Purple wire with black stripe

Connect this wire to the right rear speaker (-) negative terminal or wire.

Gray cable with red/white RCA connectors

Connect to the audio line output of any additional audio or video sound source.

Black cable with red/white RCA connectors

Provides L/R channel (front/rear) audio signal output to an additional amplifier.



Wiring (Con't.)

Note:

This unit is designed to connect 4 speakers. If the installation only requires 2 speakers, use the white and gray wire sets to connect the speakers.



WARNING

Any wires left unconnected must be taped off or capped off to prevent shorting.

DO NOT connect speaker ground wires together.

DO NOT connect speaker ground wires to the chassis of the vehicle and to the power supply ground.

DO NOT connect front and rear speaker wires together.

FAILURE TO FOLLOW ANY OF THESE WARNINGS WILL RESULT IN DAMAGE TO THIS UNIT AND VOIDS THE WARRANTY.



Wiring diagram

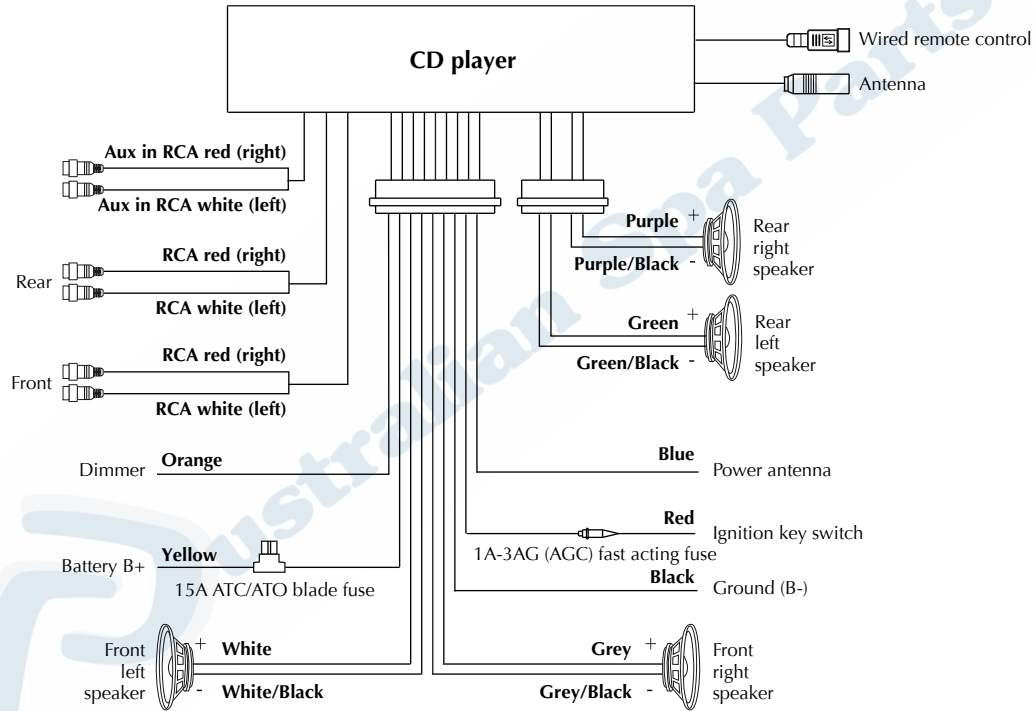



Wired remote connection

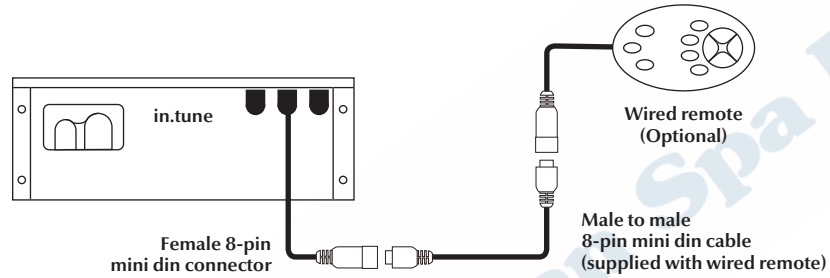



Auxiliary connection

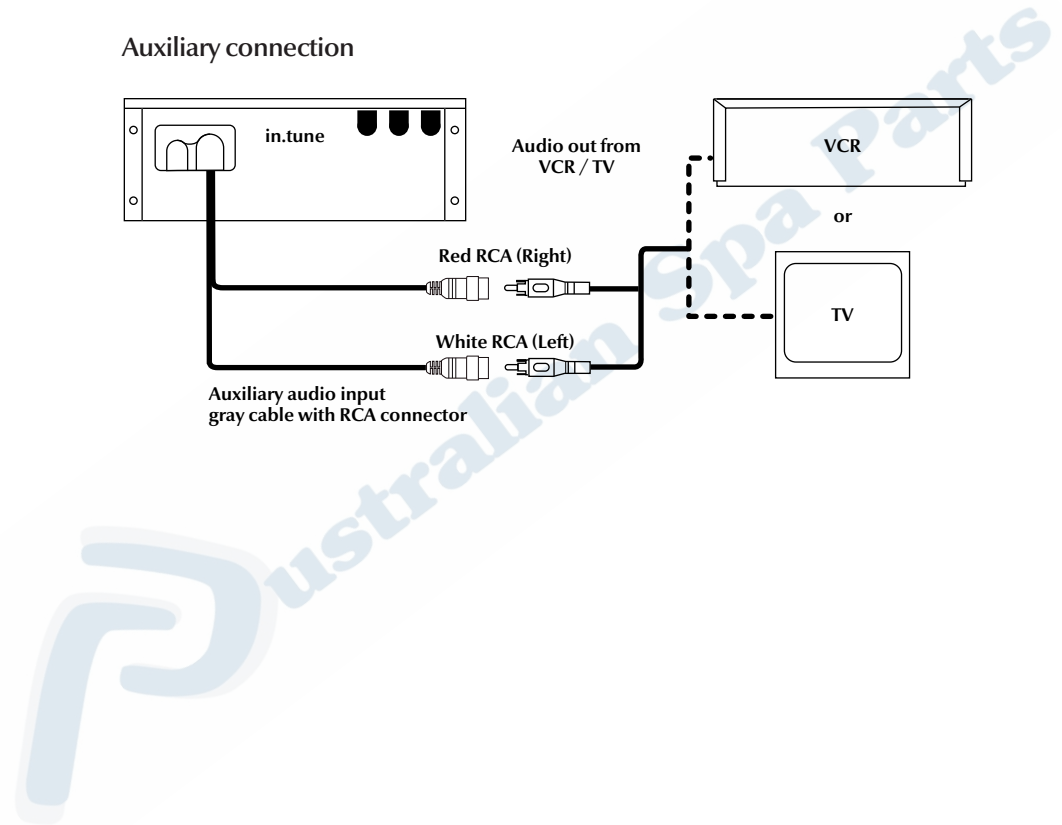
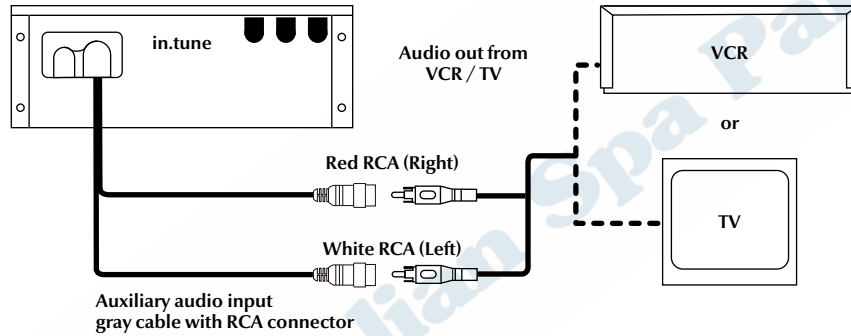

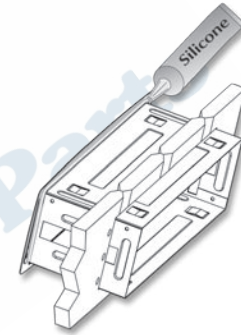
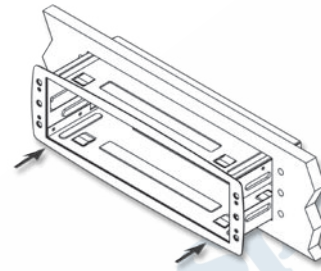
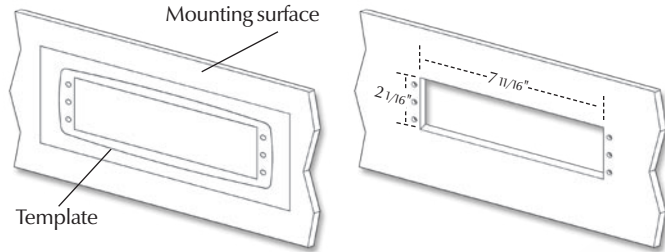

Step 1

Using the drilling template supplied with the unit, determine the mounting location and then stick the template on the location.

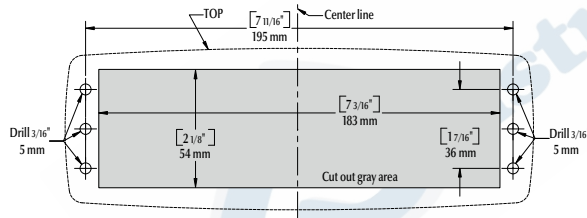

Cut and remove the hatching area on the template. Then drill six 3/16" (5mm) mounting holes in the exact position according to the mounting paper.

Step 2

Insert the mounting sleeve into the hole (installation opening).

Step 3

If the installation location is not perfectly even (e.g. wood surface), make a silicone joint between the installation location and the mounting sleeve (to avoid water leakage). Apply silicone all around the unit. Let the silicone dry and remove excess.

Note: Failure to apply silicone may damage the unit and surround equipment!

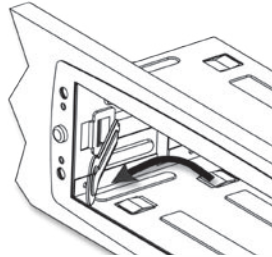
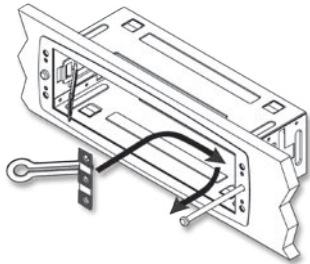

Step 4

Fixing the mounting sleeve:

- Insert mounting bracket.
- Then pull bracket towards you.
- Fix bracket with self tapping screws # 6 x 2" type A.
- Make sure the 6 holes are correctly aligned.
- Brake the installation handle by moving it back and forth.
- Repeat steps a) to e) for the other bracket.

Note: The use of an adjustable torque wrench is recommended. Torque setting: 8-12 lbs-in (0.9-1.36 N·m).

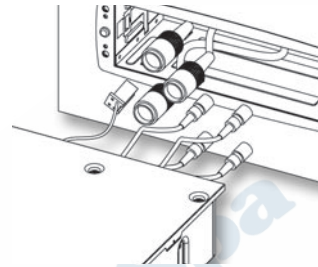

Step 5

Connect wires.

Refer to wiring section (page 27) of this manual for more details.

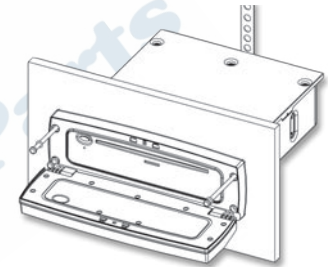

Step 6

Insert the CD player into the mounting sleeve.

Open front panel and fix CD player with (4) self tapping screws # 6 x 2" type A.

Note: The use of an adjustable torque wrench is recommended. Torque setting: 8-12 lbs-in (0.9-1.36 N·m).

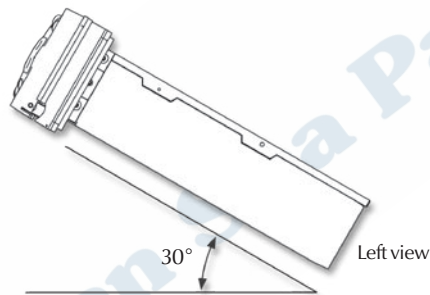
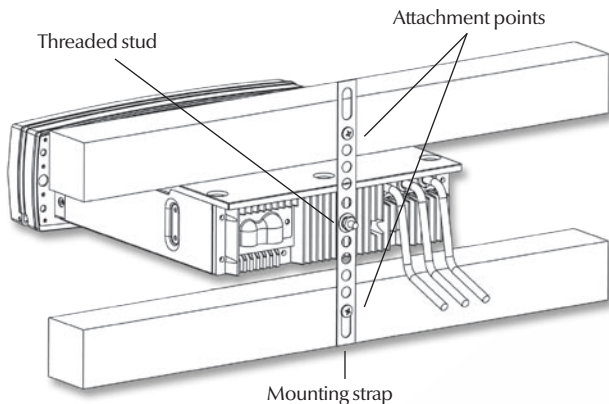

Step 7

Re-inforce the back side of the CD Player attaching the threaded stud to the metal mounting strap. Attach the other end of the strap to a solid part of the mounting area (as illustrated above). Please note that if necessary, the strap can be bent to the desired angle (to fit the mounting area).

Installation angle

If installation angle exceeds 30° from horizontal, the unit might not give its optimum performance.

Important: The in.tune must always be installed with the mounting strap firmly fixed to a solid part. Failure to do so may result in damage to the unit and annulment of the warranty.

Note: Threaded stud and mounting strap are included.

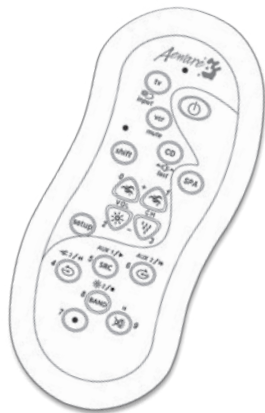

Optional IRMT-4
infrared remote control

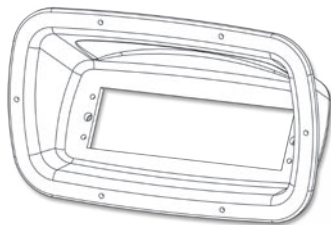

Optional panel housing
(30° mounting bezel)
for in.tune cd player

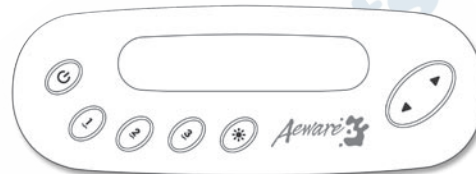

Optional in.k455
wired remote control with display



Optional in.k155
wired remote control

Sold separately.

For more information on wired and infrared remotes or other accessories, visit our website at www.aeware.ca

Designs are subject to change without prior notice.

**General specifications:**

Power supply voltage: 14,4V (11-16V allowable), negative ground

Max. current consumption: 15A

Back-up current (Ignition OFF): 15mA (Max.)

Speaker impedance: 4Ω

Operating temperature: 50°C (122°F) to -20°C (68°F)

Weight: 2.18kg (4.8lbs)

Dimensions (W x H x D):

Chassis: 178mm x 50mm x 190mm (7" x 2" x 7-1/2")

Front Panel: 212mm x 70mm x 32mm (8-3/8" x 2-3/4" x 1-1/4")

Audio specifications:

Max. power output: 50W x 4 ch (200W total)

Continuous average power output: 20W x 4 ch, into 4 Ω, 20Hz
to 20kHz, 1%TDH

Bass control: ± 10dB (100Hz)

Treble control: ± 10dB (10kHz)

Loudness contour: + 10dB (100Hz),
+ 10dB (10kHz) (at volume -20dB)

Max. preout level/load: 5V/10KΩ

Weather band:

Usable sensitivity (S/N=20dB): 2dBuV

Signal to noise ratio (S/N): 45dB

Frequency range: 162,40MHz - 162,55MHz

CD player:

Signal to noise ratio (S/N): > 65dB

Channel separation: > 50dB (at 1kHz)

Dynamic range: 80dB (at 1kHz)

Frequency response: 20Hz to 18kHz

Total harmonic distortion (THD): 0,5% (at 1kHz)

Sampling frequency: 44.1kHz

Specifications and design are subject to change without prior notice.

**FM tuner:**

Usable sensitivity (S/N = 30dB):	4 μ V
----------------------------------	-----------

Stereo separation:	30dB
--------------------	------

Signal to noise ratio (S/N):	55dB
------------------------------	------

Frequency range:

American (USA):	87,5MHz - 107,9MHz
-----------------	--------------------

Europe:	87,5MHz - 108MHz
---------	------------------

Frequency spacing:

American (USA):	200kHz
-----------------	--------

Europe:	50kHz
---------	-------

AM tuner:

Usable sensitivity (S/N = 20dB):	31 μ V
----------------------------------	------------

Frequency range:

American (USA):	530kHz - 1710kHz
-----------------	------------------

Europe:	522kHz - 1620kHz
---------	------------------

Frequency spacing:

American (USA):	10kHz
-----------------	-------

Europe:	9kHz
---------	------

Specifications and design are subject to change without prior notice.

Advanced electronics! Water resistance!



Aeware **3**
by gecko

Gecko Alliance

450 des Canetons, Quebec City (QC) G2E 5W6 Canada, 1.800.78.GECKO
9225 Stellar Court, Corona, CA 92883 USA, 1.866.639.7274

www.geckoalliance.com